

Human Gesture Controlled Car Robot

Anita Shukla^{*1}, Ankit Jain², Prajwal Mishra³ and Rahul Kushwaha⁴

1. * Pranveer Singh Institute Of Technology, Kanpur-209305, (U.P.), India. e-mail : shukla.anita27@gmail.com

2. Maharana Pratap Engineering College, Kanpur-209217, (U.P.), India.

3&4. Pranveer Singh Institute Of Technology, Kanpur-209305, (U.P.), India.

Publication Info

Article history :

Received : 15th June, 2019

Accepted : 15th Nov., 2019

DOI : 10.18090/samriddhi.v11i02.5

Keywords: PIC 16F738 microcontroller, Accelerometer, Motor driver, RF transmitter and receiver.

*Corresponding author :

Anita Shukla

e-mail : shukla.anita27@gmail.com

Abstract

In present era of development and growth, the technology has made possible for people to operate electronic devices more conveniently. Now we are able to operate machines without giving it a touch with the help of technology called Hand Gesture Recognition. Here we have devised a gesture controlled car robot which uses PIC16F738 microcontroller and accelerometer to achieve human computer interaction. In this paper we deal with development and implementation of wireless and an accelerometer based hand gesture controlled car robot using RF transmitter and receiver. Transmitter detects the movement of hand and sends the command to the receiver by RF; receiver receives the command and moves the robot accordingly. Apart from conventional approach of controlling mechanism of car robots via buttons etc., here we have developed a definite and effective algorithm for identification of the gestures.

1. INTRODUCTION

As we are moving toward more immersive computing age, many new devices are being introduced among us day by day to make user and machine more interactive. If we take an example of Smartphone then we say that it's a touch input which accelerates its growth. Designing any machine has only one objective which is to make it user friendly i.e. more the ease while interaction with machine more it is user friendly, also when Steve jobs walked up to announce the i-phone he spoke, "we're going to use best pointing device in world, we're going to use pointing device that we'all are born with, born with ten of them we're going to use our fingers". But now with immerging technology a day come when we even do not require only finger to communicate with machine, we can use our voice (latest technology introduced

by Amazon, alexa) or our body motion to interact with digital world. Here in this project we can operate the robotics car not by touch or by voice but by gesture of movement of hand using RF technology. We have prepared one transmitter unit which transmits the RF signal to the receiver unit which operates the robot accordingly.

The main objective of creating hand gesture recognition system is to develop an interactive atmosphere between human and computer where with the help of our gestures we could be able to control a car robot or accomplish any particular task[1]. How to form the resulted hand gestures to be understood and well interpreted by the computer considered as the problem of gesture interaction [2]. Human computer interaction (HCI) is also named as Man-Machine Interaction (MMI) [3, 4] refers to the relation between the human and the computer or more precisely the machine,

and since the machine is insignificant without suitable utilize by the human [3]. While designing a HCI system two key point which must be remember as mentioned in [3] were functionality and usability. The set of functions or services that the system equips to the users is known as System functionality and level and scope that the system can operate and perform specific user purposes efficiently is known as system usability [3]. For a powerful and effective performance , system must have to attain a suitable balance between these concepts. [3]. Gestures which is used as communication tool between human and machines using language[5] can be static which require less computational complexity [6] or dynamic which are more complex but suitable for real time environments [6,7]. We can employ different methods for acquiring necessary information for recognition of gestures system [8,9]. Some methods use devices such as data glove devices and color markers , some are based on the appearance of hand using skin colour to easily extract comprehensive description of gesture features [8]. On comparing these methods with methods mentioned before we find these methods easy, natural and less cost comparing [8]. Some recent reviews explained gesture recognition system applications and its growing importance in our life [10] especially for Human computer Interaction HCI, Car robot control, games and surveillance, using different tools and algorithms [9, 11]. This work is an example of the advancement of the gesture recognition systems including the discussion of different stages required to build a complete system with less erroneous using different algorithms.

2. FEATURES OF THE PROPOSED SYSTEM

In this project we use PIC16F738 microcontroller in both transmitter and receiver sections. In

transmitter we use one ADXL335 accelerometer which detect the movement of the hand and sends the analog signal value accordingly through the RF transmitter to the receiver section. Receiver section has RF receiver which will receive these signals and decode it by the microcontroller. We use two motor driver L298IC which will operate the four motors of the robot front, back, left, right and stop accordingly.

If we tilt our hand in forward direction then our robot moves forward. If we tilt our hand in backward direction then our robot moves backward, similarly for the left and right movement. If we hold stable flat our hand then our robot stops the movement. PCB of this project prepare on DIP trace software, programming is done in PIC microcontroller by embedded C language.

3. DEVELOPMENT OF FLOW CHART

The flow chart which we develop is very simple which is shown in Fig.1 (a) and (b) for transmitter and receiver sections respectively.

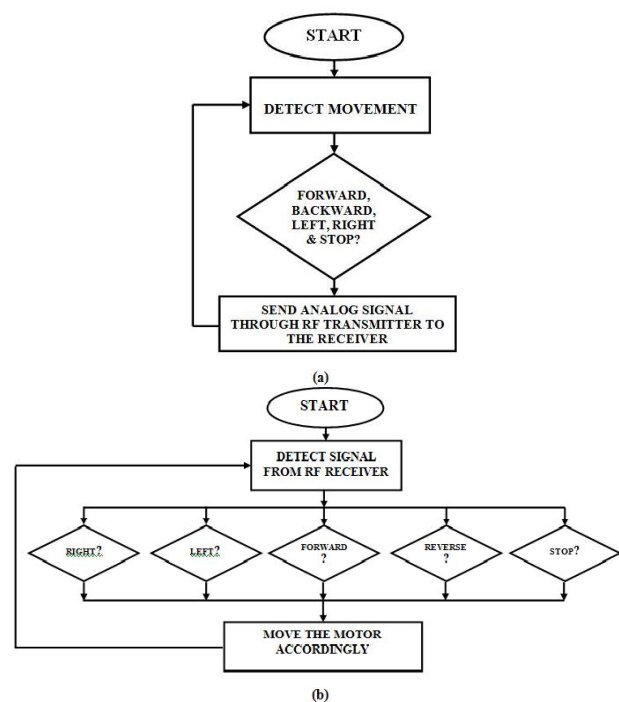

Fig.1: Flowcharts (a) Transmitter (b) Receiver

4. IMPLEMENTATION OF HARDWARE

Following are the major components which we are used in this project:

- 4.1 PIC16F738 microcontroller
- 4.2 ADXL335 accelerometer
- 4.3 RF transmitter and receiver module
- 4.4 L298 Motor driver IC
- 4.5 DC motors
- 4.6 Voltage regulator 7805 IC

4.1 PIC16F738 microcontroller

Pin diagram of PIC16F738 is shown in Fig. 2. 8-bit timer/counter with 8-bit prescaler along with 10-bit multi-channel Analog-to-Digital converter is the part of PIC16F738. SSP an acronym for Synchronous Serial Port with SPI (Master (Master/Slave)™ mode) and I2C is also an integral part of it. It also contains a Universal Synchronous Asynchronous Receiver Transmitter (USART/SCI) with 9-bit address detection.

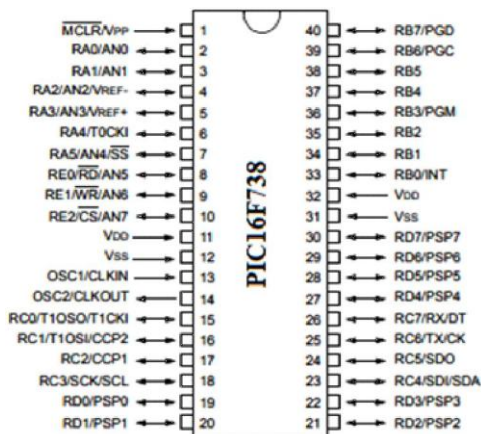

Fig.2: PIC16F738 Microcontroller IC

4.2 ADXL335 Accelerometer

ADXL335 is shown in Fig. 3. In the centre of the module there is a small, low power triple axis MEMS accelerometer from analog devices having very low noise - ADXL335. The range of the sensor covers the range of ± 3 g. static acceleration

due to gravity in tilt-sensing applications along dynamic acceleration resulting from motion, shock, or vibration could be measured very accurately.

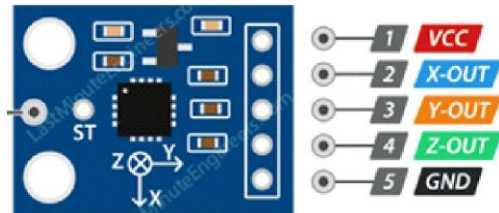

Fig.3: ADXL335 accelerometer

4.3 RF transmitter and receiver module (434MHz)

RF module is shown in Fig. 4. As the name suggests, it operates at Radio Frequency. The frequency range variation is from 30 kHz to 300 GHz. Variations in the amplitude of carrier wave signifies digital data in the given RF system. This type of modulation is called Amplitude Shift Keying (ASK). Transmission through RF has merits over IR (infrared) because of many reasons. Firstly, signals through RF can travel larger distances making it suitable for long range applications. Also, while IR mostly operates in line-of-sight mode, RF signals have property to travel even if there is an obstruction between transmitter & receiver. The other merit is that RF transmission is more strong and reliable than IR transmission. Unlike IR signals, RF communication uses a specific frequency which are affected by other IR emitting sources. RF transmitter and an RF receiver are main constituent parts of this RF module. The pair of transmitter/receiver works at operating frequency of 434 MHz. the antenna connected at pin4, is used by RF transmitter to receive serial data and transmit it wirelessly through RF. The rate of transmission is 1Kbps - 10Kbps. The data transmitted is received by an RF receiver which operates at the same frequency as that of the transmitter.

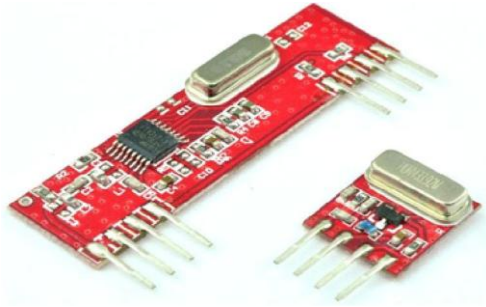

Fig.4: RF Module (Transmitter & Receiver) (434MHz)

Pin diagram for RF transmitter and receiver is shown in Fig.5.

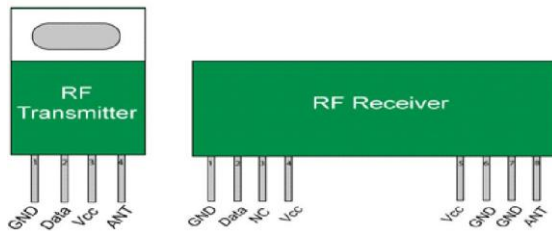

Fig.5: Pin Diagram for RF Transmitter and Receiver

4.4 L298 Motor Driver IC

With the help of L298N which is a dual H-Bridge motor driver the speed and direction control of two DC motors at the same time is done. The DC motors having voltages between 5 and 35V, with a peak current up to 2A could be driven using this module. The L298N is shown in Fig. 6.



Fig.6: L298 Motor Driver

4.5 DC Motors

The conversion of direct current (electrical energy) into mechanical energy is done with the help of a *dc motor*. DC motor is shown in Fig 7. It

works upon the principle of Lorentz Law. According to law when we place a current-carrying conductor in a magnetic field it experiences a mechanical force and the direction of this force is given by Fleming's Left-hand rule.



Fig.7: DC Motor

Motors are used wherever we wish to convert electrical energy into mechanical energy. This is achieved by allowing a current to pass through a coil and producing a magnetic field that spins the motor. The speed of dc motor is measured in revolutions per minute (RPM). As the supply voltage increases, the speed of the dc motor increases. However we cannot exceed the supply voltage beyond rated voltage. The speed of dc motor depends on load. At no-load the speed of dc motor is highest. As the load is increased the speed decreases. Overloading of the dc motor can damage it because of excessive heat generated due to high current consumption.

4.6 Voltage Regulator 7805 IC

A voltage regulator is a simple device with only three terminals, but it is in fact a very complex integrated circuit. It is used to convert varying input voltage into a constant 'regulated' output voltage. Voltage regulators are available in a variety of outputs like 5V, 6V, 9V, 12V and 15V etc. The **LM78XX** series of voltage regulators are designed for positive input. Fig. 8 shows a voltage regulator.

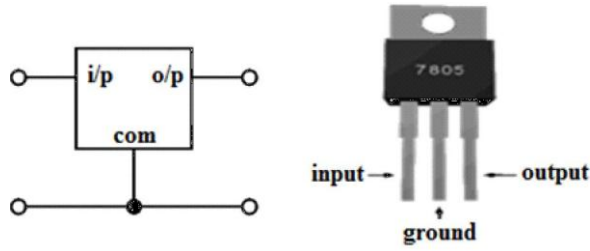

Fig.8: Voltage Regulator

The circuit diagram for transmitter and receiver is shown in Fig. 9 (a) and (b) respectively.

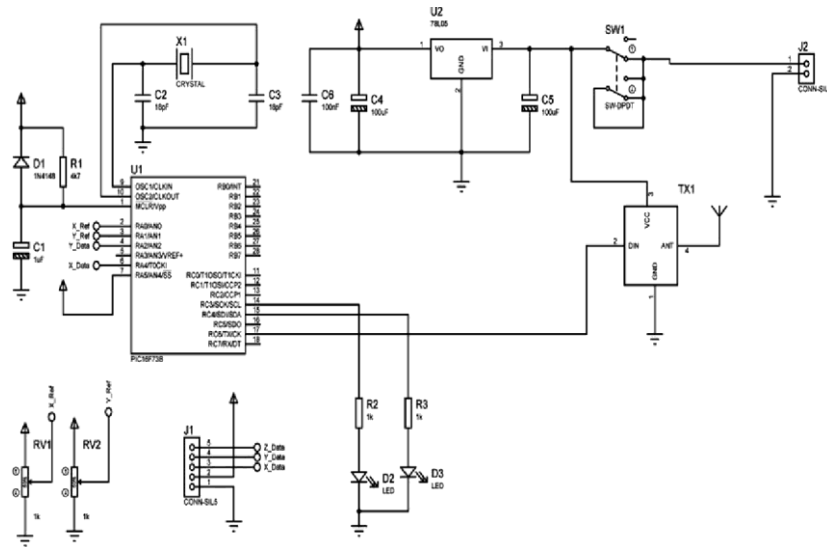

Fig.9: (a) Transmitter Circuit

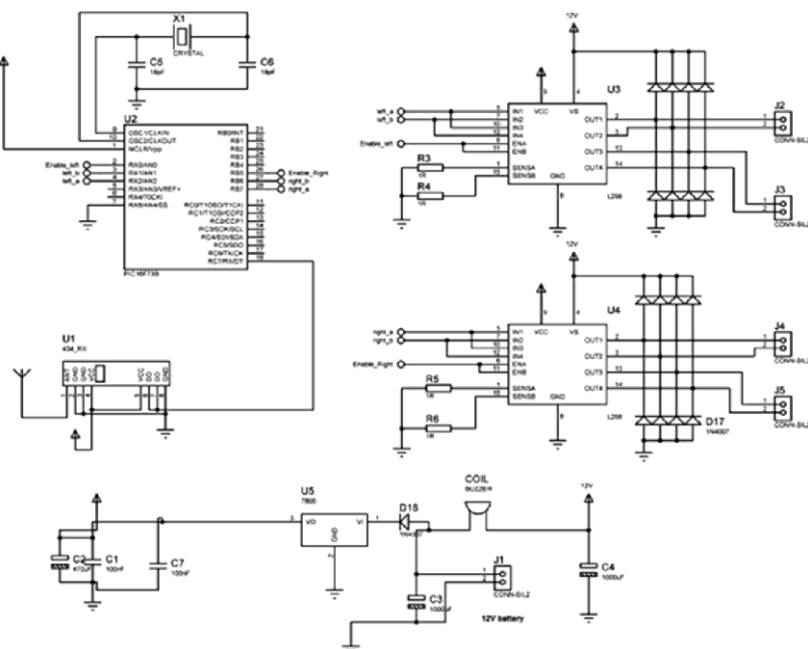
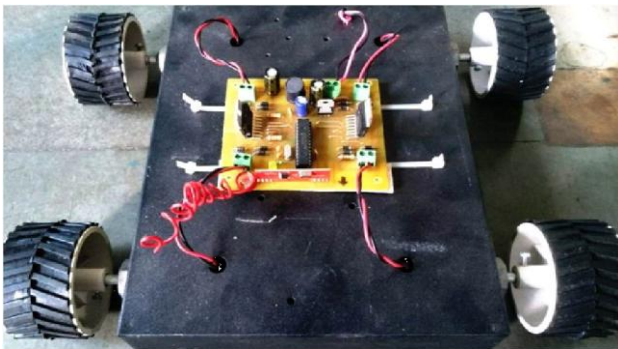

Fig.9: (b) Transmitter Circuit

Original picture of developed project is shown in Fig. 10 (a) transmitter and (b) receiver.



(a)



(b)

Fig. 10 : (a) Transmitter and (b) Receiver

5. CONCLUSION

In present work we have developed a car robot which is controlled by human hand gesture. The movement of hand fully controls the car robot and the response of car robot towards hand gesture is satisfactory. The car robot follows the signals properly and responses in left, right, forward and backward directions very well. The acceleration of the Car Robot can also be monitored.

6. FUTURE SCOPE

Robotics could play a major role in our day to day life and in some specific areas like medical field. The proposed system could be very much useful in the medical field. it could be employed

to reduce man power in medical field and also to take care of patient in absence of specialist/ surgeon. There are various application of hand gesture recognition which technology adopt and changes, like some are.

- 3-D designing
- Smart TV/Computers
- Smart helmets
- Hardware controls
- Hand gesture also allows doctor to manipulate digital imaging during medical procedure instead of touch screen or computer keyboard.
- Gesture technology proves more helpful for physically handicapped people as it provide them medium to efficiently convey facts and feelings.

REFERENCES

- [1] Murthy, G. R. S., & Jadon, R. S. (2009). A Review of Vision Based Hand Gestures Recognition; *International Journal of Information Technology and Knowledge Management*, 2(2),405- 410.
- [2] Garg, P., Aggarwal, N., & Sofat, S. (2009). Vision Based Hand Gesture Recognition: *World Academy of Science, Engineering and Technology*, 49, 972-977.
- [3] Fakhreddine, K., Milad, A., Jamil, A. S., & Mo Nours, A. (2008). Human- Computer Interaction: Overview on State of the Art: *International Journal on Smart Sensing and Intelligent Systems*, 1(1).
- [4] Human computer interaction. (2019, December 2). Retrieved from https://en.wikipedia.org/wiki/Human%20%80%93computer_interaction
- [5] Mokhtar, M., Hasan, Pramoud, K, Misra, (2011). Brightness Factor Matching For Gesture Recognition System Using Scaled Normalization: *International Journal of Computer Science & Information Technology (IJCSIT)*, 3(2).
- [6] Xingyan, Li.(2003).Gesture Recognition Based on Fuzzy C-Means Clustering Algorithm: *Department of Computer Science. The University of Tennessee Knoxville*.

- [7] Mitra, S., & Acharya, T., (2007). Gesture Recognition: A Survey: *IEEE Transactions on systems, Man and Cybernetics, Part C: Applications are views*, 37(3), 311- 324
- [8] Simeci, G., Wysoski, Marcus, V., Lamar, Susumu, K., & Akira, I.wata, (2002). A Rotation Invariant Approach On Static-Gesture Recognition Using Boundary Histograms And Neural Networks: *IEEE Proceedings of the 9th International Conference on Neural Information Processing, Singapura*.
- [9] Joseph J.,& LaViola., Jr.(1999). A Survey of Hand Posture and Gesture Recognition Techniques and Technology: *Master Thesis, Science and Technology Center for Computer Graphics and Scientific Visualization, USA*.
- [10] Rafiqul Z., Khan., Noor A.,& Ibraheem.(2012). Survey on Gesture Recognition for Hand Image Postures:*International Journal of Computer And Information Science*, 5(3)
- [11] Thomas B., Moeslund., & Erik G. (2001).A Survey of Computer Vision-Based Human Motion Capture: *Elsevier, Computer Vision and Image Understanding*, 81, 231–268.
- [11] Nalluri, S. K., & Parasaram, V. K. B. (2016). Early Approaches to Robotic Process Automation in Enterprise Systems. *International Journal of Humanities and Information Technology*, 1(01), 12-28.

