

Design of Automated Car Using Arduino UNO

K.Sumanth Naag^{*1}, Thejaswini P²

^{1,2} Department of ECE, JSSATE, Uttarahalli-Kengeri Road, Bangalore 560060, India; e-mail : sumanthnaagk@gmail.com, thejaswinip@jssateb.ac.in

ABSTRACT

Rapid growth in automation has resulted in the advancement of Automated cars, which inherits few features of driverless Autonomous cars. Experts have estimated that automated cars reduce car thefts and accidents by upto 90%, i.e. saving 30000 lives every year. Hence, we propose an Automated car built using Arduino Uno controller which involves fuel monitoring, tyre pressure monitoring, control of headlights and reduction of car theft through voice-controlled door lock. This paper describes the application of LDR sensor, level sensor and tyre pressure sensor for building the proposed automated car. The output of the mentioned sensors is intimated to the driver through a voice output making use of APR 33A3 voice recording module.

Keywords: Automated car, Arduino Uno, Voice-control, Fuel sensor, Tyre pressure sensor.

SAMRIDDHI : A Journal of Physical Sciences, Engineering and Technology, (2020); DOI : 10.18090/samriddhi.v12iS3.13

INTRODUCTION

Automobile provides an extraordinary platform for technology. Each progression of the car's transformation represents the potential for remarkable moments among engineers and innovators. Over the period of time, cars have been considered of as many things from horseless carriages to hot rods, and now we're starting to consider them as intelligent, connected, and autonomous ways to get around. An autonomous car is known as a self-governing vehicle or a robot vehicle which can guide on its own without human assistance. This kind of vehicle may pave the way where computers take over the art of driving.

Autonomous cars [1] functions on various kinds of technologies [2]. They can be built with GPS sensing knowledge to help the navigation. Collisions may be avoided by the utilization of sensors and other equipments. A vehicle can also display information to driver in new and inventive ways through augmented reality. But a major drawback is that it's very expensive for a common man to afford. Automated cars are making their move into automotive market place. Over the decades, many additional features and controls have been added to the automobiles, to make them economic and efficient. Hence our idea is to build an automated

Corresponding Author : K.Sumanth Naag, Department of ECE, JSSATE, Uttarahalli-Kengeri Road, Bangalore 560060, India; e-mail : sumanthnaagk@gmail.com

How to cite this article : Naag, K.S., Thejaswini, (2020). Design of Automated Car Using Arduino Uno *SAMRIDDHI : A Journal of Physical Sciences, Engineering and Technology, Volume 12, Special Issue (3), 57-61.*

Source of support : Nil

Conflict of interest : None

car inheriting few of the features of autonomous car making it cost effective and efficient.

METHODOLOGY

The proposed automated car involves the use of Arduino Uno [3] [4], LDR sensor, level sensor, pressure sensor, LCD, APR33A3, solenoid lock and bluetooth module. The block diagram of the proposed work is shown in figure 1.

Arduino Uno [5] is basically a microcontroller which is based on microchip ATmega328P microcontroller and developed by arduino.cc. The board is comprised of 14 digital and 6 analog input output pins which can be interfaced to various electronic circuits. It is programmable with Arduino IDE. This board is used since it is inexpensive, provides simple clear programming environment,

©The Author(s). 2020 Open Access This article is distributed under the term of the Creative Commons Attribution 4.0 International License (<http://creativecommons.org/licenses/by/4.0/>), which permits unrestricted use, distribution, and non-commercial reproduction in any medium, provided you give appropriate credit to the original author(s) and the source, provide a link to the Creative Commons license, and indicate if change were made. The Creative Commons Public Domain Dedication waiver (<http://creativecommons.org/publicdomain/zero/1.0/>) applies to the data made available in this article, unless otherwise stated.

provides cross platform, open source and extensible for software and hardware.

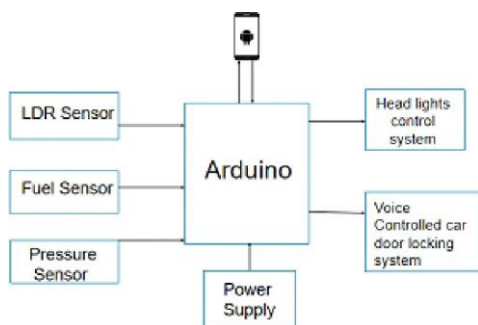

Figure 1: Block diagram of the proposed automated car

The LDR sensor detects the changes in the event and sends the information to the Arduino board. Depending upon the information given to the Arduino, the headlights are controlled. The level sensor senses the fuel level and tyre pressure sensor MPS2000 senses the pressure in the tyre and sends the information to Arduino. The resulting processed outputs are displayed using LCD[6] and outputted through voice when fuel and pressure levels fall below the threshold value using an APR33A3 module. Voice commands are given through the smart phone's speaker using an android VoiceBot application which communicates with Arduino to control the door locking unlocking system through HC-05 Bluetooth module. Below sections discuss about the implementation of the proposed method.

Automatic headlights on-off mechanism using LDR sensor

LDR stands for Light Dependent Resistor is used to monitor the light intensity[7]. This sensor is built up of semiconductor material with high resistance. In the dark, its resistance value is of several mega ohms and in the light, resistance is as low as few hundred ohms. It works on the principle that when the light intensity beyond the threshold value decreases, the resistance of the LDR increases. As this resistance increases with the steady resistance, it causes voltage drop across LDR to increase resulting in switching ON the headlights[8].

Depending upon the external environment the set threshold value is 150 for the LDR sensor in our work. When the atmospheric intensity is lower than the set threshold value, headlights automatically glows and when the atmospheric intensity is higher than the set threshold value, headlights automatically turns off. The output is displayed in LCD unit.

Fuel monitoring system using level sensor

Level sensor is used to detect the level of liquids and other fluids. They are used in monitoring and regulating the levels of a precise free-flowing substance within a contained space.[9] There are different types of liquid level sensor used to detect the point level of a liquid. Two ways of measuring levels of liquid are by continuous values and point values. Determination of the perfect amount of liquid at a certain point within a stated range is by continuous level sensors. While point level sensors is used in determination of the substance whether it is above or below the sensing point. This application of level sensors is used in our work to monitor the fuel level in the tank.[10]

The level sensor is defined as a transducer which uses a low voltage, usually by a source of power supply. We are considering 4 leads; one acts as ground lead and the rest are the reference leads. When the fuel comes in contact with the ground lead and one of the reference leads, conductivity starts and the internal circuit completes. This sensed information is sent to Arduino and the output is displayed through LCD and voice output only if the fuel level falls below the ground lead indicating 'low fuel' using APR33A3 voice recording module.



Figure 2: Level Sensor

2.3 Tyre pressure monitoring using mps2000 sensor

A pressure sensor is a sensor which detects the pressure in gases. It normally acts as a transducer which generates a signal as a function of pressure imposed.[11][12]

In our proposed work, MPS2000 is used for pressure monitoring. The sensor features silicon pressure sensor in 6pin dual in-line packages. Features of MPS2000 are wide operating temperature range of

-40 to +85°C, solid state reliability, ease of use, non-corrosive with most of gases and dry air.



Figure 3: MPS2000

Constant voltage excitation makes MPS2000 to produce a voltage output proportional to the applied input pressure. The output voltage is interfaced to Arduino and the outputs are displayed on LCD. Whenever pressure level falls below the threshold value it is intimated to the driver through a voice output as 'low pressure' with the use of the APR33A3 voice recording module.

APR33A3 is a single chip with a high quality voice record and playback module as shown in figure 4. It consists of 8 channels in which a voice can be recorded in each channel for 1.3 minutes. In total, a 11 minutes of voice recording can be recorded with the assist of this module. It has built in audio recording microphone amplifier. Power saving is supported by this module with the help of power-down mode. [13][14]

To record a voice message in the IC, a low signal is applied to the record pin from one of the channels of the IC from Arduino. A timer can be set for the amount of duration required, to keep the pin low. After recording, the record pin has to be made high and this stores the message in that pin. To playback the voice, apply low signal to that pin of channel which holds the message.



Figure 4: APR33A3 module

Voice-controlled door locking-unlocking system

Car thefts can be reduced by securing the car. For this purpose, our target is to secure the door of the car through voice, making it a voice-controlled door locking unlocking system. The system is comprised of Bluetooth HC-05 module, solenoid lock and makes use of android VoiceBot application.

HC-05 is a Bluetooth Serial Port Protocol module. its applications are mainly seen in transparent wireless communication. It is a 6-pin module which has MASTER/SLAVE configuration which controls the data transfer.[15]

As a MASTER configuration, the connectivity can be initiated and accepted from other Bluetooth devices. Whereas, the SLAVE module cannot set up a connection but it accept connections from other devices. This configuration of the module can be configured only by AT commands of the HC-05. [16][17] The features of the module are that it secures the connection by pairing to the other device by a password, where default password is 1234. A single person can connect to the module at a time which makes it more secure.

Solenoid lock is used in our proposed work which uses electronic-mechanical locking mechanism. It is categorized by the use of solenoid to lock and unlock. [18] A solenoid is a coil of wire which is used as an electromagnet. The device uses the electric current to create magnetic field in order to produce a linear motion which is used for locking-unlocking purpose. The field exerts force on plunger. As a outcome, it unlocks making the plunger move to the centre of the coil. Among the three types of solenoid lock, a power-on unlocking type is used which remains locked during power failure or wire disconnection making it a great use in crime prevention like car thefts. The solenoid is driven by Arduino to lock/unlock based on the voice commands[19] given in the program.

Our work utilizes all these features of the Bluetooth module and the lock, along with android VoiceBot application[20] to control the locking-unlocking system through voice. The steps are: 1. Open the VoiceBot application in smartphone. 2. Pair the Bluetooth module and the smartphone via Bluetooth secure connection using the default password. 3. Voice command UNLOCK/LOCK is given through the microphone of the smartphone, as a result, the Arduino drives the solenoid to unlock/lock.

RESULTS

The proposed work is implemented and tested. The results are discussed below. Fuel monitoring system monitors the amount of fuel present in the tank. Figure 5 shows the output displayed on LCD.

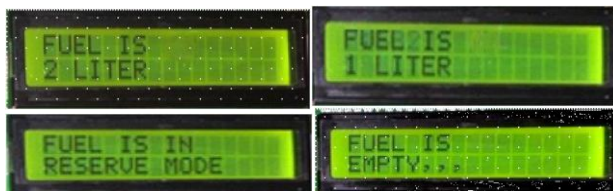

Figure 5: Output of fuel monitoring on LCD

Tyre pressure monitoring system monitors the pressure of the tyre and the output is viewed in LCD. From figure 6, P:682 indicates low pressure.



Figure 6: Output of tyre pressure monitoring on LCD

CONCLUSION

Over the decades, additional features and controls are incorporated to the automobiles, to make them economic and efficient. Autonomus cars are making their way into market. The main drawback of Autonomus cars are cost. Hence our proposed Automated car inherits few of the features of autonomous car making it cost effective and efficient. Automated car was designed using Arduino Uno controller which involved fuel monitoring, tyre pressure monitoring, control of headlights and reduction of car theft through voice-controlled door lock-unlock system. The design was implemented and tested. The proposed automated car has the features of high-end autonomous car at an affordable price. It reduces car thefts and accident rates making it cost effective.

REFERENCES

- [1] Sadigh, D., Sastry, S. S., & Seshia, S. A.: Verifying Robustness of Human-Aware Autonomous Cars. IFAC-PapersOnLine, 51(34), 131-138.(2019)
- [2] H. Drezet, S. Colombel and M. Avenel: "Human-Man Interface Concept For Autonomous Car," 2019 IEEE International Conference on Consumer Electronics (ICCE), Las Vegas, NV, USA, 2019, pp. 1-5.(2019)
- [3] Badamasi, Y. A.: The working principle of an Arduino. In: 2014 11th International Conference on Electronics, Computer and Computation (ICECCO) (pp. 1-4). IEEE.(2014, September)
- [4] Wireless Car system based on Arduino Uno, Lang Chen;Jianbo Zhang ;Yao Wang: 2ndIEEE Advanced Information Management, Communicates, Electronic and Automation Control Conference (IMCEC) .(2018)
- [5] Kumar, R. H., Roopa, A. U., & SATHIYA, D. P. :Arduino ATMEGA-328 microcontroller. International journal of innovative research in electrical, electronics, instrumentation and control engineering, 3(4), 27-29.(2015).
- [6] Vehicle computer system with transparent display. Fitch T. R., & Oberpriller, M. L: U.S. Patent No. 9,235,553. Washington, DC: U.S. Patent and Trademark Office.(2016).
- [7] Optimal light power consumption using LDR sensor, Ghassan Maan Salim ;Hashimah Ismail; Niranjan Debnath;A. Nadya: IEEE International Symposium on Robotics and Intelligent Sensors (IRIS) .(2016).
- [8] Saad, M., Farij, A., Salah, A., & Abdaljalil, A. :Automatic street light control system using microcontroller. In: 1st International Conference on Machine Design and Automation (pp. 92-96).(2013).
- [9] Petrol level indicator with automated audio alert system. R. Kalidoss ; R. Praniha ; P. Raveena ; C. Revathy: International Conference on Wireless Communications, Signal Processing andNetworking (WiSPNET), IEEE.(2017).
- [10] Sloan, T., & Forsberg, C., :U.S. Patent No. 9,850,845. Washington, DC: U.S. Patent and Trademark Office, "Systems and methods for monitoring and controlling fuel systems,(2017)"
- [11] Nouman Naim Hasan ; Adeel Arif ;Muhammad Hassam ; Syed Shabeeh Ul Husnain ; Usman Pervez, :International Conference on Communications, Computing and Control Applications (CCCA), IEEE, "Implementation of tire Pressure Monitoring System with wireless communication".(2011)

- [12] Carl A. Fiorletta, "Tire pressure monitoring system".
- [13] Kumar, K. S. :Web Based Industrial Parameters Monitoring System through WSN and Arm7 with Voice Alerting. *International Journal of Research*, 3(18), 1263-1272.(2016).
- [14] Satwashil, K. S., & Pawar, V. R. (2017, June). English text localization and recognition from natural scene image.: *International Conference on Intelligent Computing and Control Systems (ICICCS)* (pp. 555-559). IEEE.(2017)
- [15] Approach for performance investigation of different Bluetooth modules and communication modes by Ehsan Ullah Warriach ;Stefan Witte, In: 2008 4th International Conference on Emerging Technologies, IEEE.
- [16] Gaikwad, P. V., & Kalshetty, Y. R. : Bluetooth based smart automation system using Android. *International Journal of Science and Research*, 6(5).2017
- [17] Parasaram, V. K. B., & Nalluri, S. K. (2016). A Comparative Analysis of Risk Management Frameworks in Enterprise IT Projects. *SAMRIDDHI : A Journal of Physical Sciences, Engineering and Technology*, 8(02), 147-155. <https://doi.org/10.18090/samriddhi.v8i2.7149>
- [18] Chakraborty, D., Sharma, K., Roy, R. K., Singh, H., & Bezboruah, T. : Android application based monitoring and controlling of movement of a remotely controlled robotic car mounted with various sensors via bluetooth. In: 2016 International Conference on Advances in Electrical, Electronic and Systems Engineering (ICAEEES) (pp. 170-175). IEEE.(2016, November).
- [19] Nalluri, S. K., & Parasaram, V. K. B. (2016). Early Approaches to Robotic Process Automation in Enterprise Systems. *International Journal of Humanities and Information Technology*, 1(01), 12-28. <https://doi.org/10.21590/ijhit.01.01.06>
- [20] Hashim, N., Azmi, N. F. A. M., Idris, F., & Rahim, N. : Smartphone Activated Door Lock Using Wifi. *ARNP Journal of Engineering and Applied Sciences*, 11(5).(2016).
- [21] Barth, J., Ferrara, P., Guerreiro, J., Iotova-Gagnaire, A., Pula, M., & Rohrbaugh, S.: "Voice Control for Emergency Vehicle"(2019).
- [22] Ýskender, A., Üçgün, H., Yüzgeç, U., & Kesler, M. :Voice command controlled mobile vehicle application. In: 2017 International Conference on Computer Science and Engineering (UBMK) (pp. 929-933). IEEE.(2017, October).