

Online Food Ordering System for College Canteen

Rupali B. Kale*, Ruchika K. Balwade, Vipin B. Gawai

Electronics and Telecommunication Department, All India Shri Shivaji Memorial Society's College of Engineering, Pune-411001, Maharashtra, India

ABSTRACT

The aim of the online food ordering for the college canteen is to automate the current manual system with the help of electronic equipment and full- edged computer software, fulfilling their needs, so their valuable data will be kept for an extended amount with straightforward accessing and manipulation of identical. Basically, the paper describes how to manage for an excellent presentation and higher services for the clients. In our proposed system we are using Raspberry Pi controller, quick response (QR) code scanner, liquid-crystal display (LCD), and Wi-Fi. Raspberry Pi is the main controlling element in the paper.

Keywords: Android application, Raspberry Pi 3b+, Software, Token number display.

SAMRIDDDHI : A Journal of Physical Sciences, Engineering and Technology (2020); DOI: 10.18090/samriddhi.v12iS2.13

INTRODUCTION

An online food ordering system for the college canteen has been established to override the problems active manual system. This code is supported to eliminate, and in some cases, decreases the hardships two-faced by this existing system. Moreover, this technique is supposed for the particular needs of the faculty to hold out operations throughout a graceful and effective manner.

The application is reduced the most quantity as potential to avoid errors whereas returning into the knowledge. It conjointly provides error message whereas coming into invalid information. No formal data is required for the customer to use this technique. Thus, by this all it proves it's simple. Online food ordering system for the college canteen as represented on highest of, will cause error-free, safe, reliable, and quick management systems. It will assist the user to target their different actions rather focus on record-keeping. Thus, it will help the organization in higher consumption of resources.

Every organization, whether or not huge or small, has challenges to beat and managing the knowledge of workers, college canteen, meal type, bill payment, and canteen workers. Each college canteen management system has totally different school canteen needs; so, we tend to style select worker management systems that area unit custom-made to your social control supplies. This can be created to help in planned to come up with and can assist you make sure that your organization is supplied with the correct level of data and details for your future goals. Also, for those busy managers United Nations agency area unit invariably on the go, our systems arise with remote access options, which can allow you to manage your personnel anytime, within the least times. These systems will finally allow you to be raised to manage resources.

Corresponding Author: Rupali B. Kale, Electronics and Telecommunication Department, All India Shri Shivaji Memorial Society's College of Engineering, Pune-411001, Maharashtra, India, e-mail: Rupalibkale7@gmail.com

How to cite this article: Kale, R.B., Balwade, R.K., Gawai, V.B. (2020). Online Food Ordering System for College Canteen. *SAMRIDDDHI : A Journal of Physical Sciences, Engineering and Technology*, 12(SI-2), 64-68.

Source of support: Nil

Conflict of interest: None

EXISTING SYSTEM

The existing system does not enable customers to understand their payment details, order details, and their due payment at intervals the canteen. During this system, admin does not have the ability to update or create changes to any data and conjointly not having the facility to feature, modify or delete any services that square measure being provided at intervals their canteen. As admin does not have the ability to know what amount ordered is out there is on the market is obtainable is accessible is ordered for explicit product or services that square measure being available at intervals their search, they are doing ineffectual, to build, to form, to create, fast action, and by that it will make their huge loss for his or her daily business transactions.

PROPOSED SYSTEM

This system will allow their users to know what items are available under their canteen shop and its price at which they are available. In the meantime, customers are also provided with the option of buying a specific item. If the customer enters the yes option, then they can enter the number of quantities for each product they will be able to get the bills for

the items which they have purchased and finally back up their purchased items from the pickup center. Thus, the admin will only be having the duty to visualize the final bills and supply higher services to their new and existing customers.¹⁻³

LITERATURE SURVEY

In the canteen management system using an e-wallet,¹ inside the faculty canteen, heaps of your time are wasted in queues. The planned application is principally helpful for reducing the time wasted waiting within the queue by causing the orders onto the room, putting orders prior to, and by providing a post-paid billfold facility that saves time spent in the tendering amendment, now are frequently used for the other smart purpose. The e-wallet planned within the application is secured employing a 2,048-bit encoding theme.

Implementing customizable online food ordering system using web-based application paper,³ this paper gives digital restaurant and inter-restaurant navigation exploitation good phones to customers, rather than exploitation PDAs to interface with customers, exploitation good phones or pill to supply necessary interfaces for the client to look at and order menu. With a non-public login system, customers will read and build an order and receive updates in the time period and collect receipts right from the good phone itself.

In canteen consuming management system design based on CAN bus and RFID,⁴ the advanced technology expensing is employed principally within the management system of the canteen within the domestic and foreign. The technologies area unit contacting the IC card, the non-contacting IC card, and also the RS485 bus. However, this type of expensing management system additionally has some defects. To unravel the slow reading speed, damage, dangerous secrecy, and slow transmission speed than on, an intelligent expensing and management system of canteen supported will bus and wireless frequency technology is intended.

SYSTEM DESIGN

The block diagram of our paper is shown in Figure 1. It consists of five major blocks, i.e., Android app, QR scanner, Raspberry pi 3B+, LCD, and speaker/sound. The android app is built with

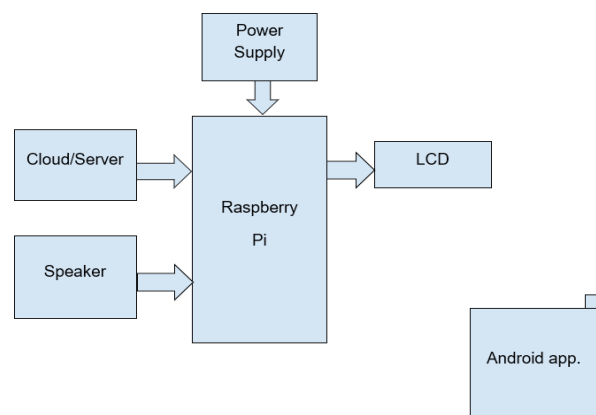

Figure 1: Block diagram

Java programming, which is basically media through which students are going to order their food and make respective payments of their orders. The Android app is generally the menu of the canteen.⁴

Explanation of each Block

Power Supply

A power supply is an electronic device that provides electric energy to the connected load. The main function of a power supply is to convert one form of electrical energy into another and as a result power supply is sometimes referred to as electric power converters.⁵

Raspberry Pi

The Raspberry Pi is a minicomputer board developed in the UK by the Raspberry Pi foundation. It has a Broadcom BCM2835 system-on-chip (SoC), which includes an ARM1176JZF-S 700 MHz processor, video-core LV GPU, originally 256 MB of RAM, which was later upgraded to 512 MB. It uses an SD card for booting and persistent storage. Raspberry Pi supports OS, like Linux, Android, Arch Linux ARM, and Unix.

QR Scanner

A QR code is known as a quick response code is a type of barcode that contains a matrix of dots, which can be scanned using a QR scanner or smartphone with built-in camera. All QR codes have a square shape and include three square outlines in the bottom left, top left, and top right corner These square outlines define the orientations of the code.

Display

The most popular method for displaying numerical data that can be understood readily by the user or operator uses a 7-segment configuration to form the decimal characters 0 through 9. The display unit comprises of BCD-to-7-segment decoder/driver and two sets of 7-segment displays.

Speaker

A speaker is an electronic transducer that converts an electrical signal to a sound signal which is audible to all. The speakers are needed here to announce the order number at the canteen side.

System Working

Ordering Food via Android App

Initially, students have to order their food through this app. There are two menus for both veg and non-veg dishes. Students have to select the dish which they want to order and then go for the payment mood. We have provided only payment mood. Then, they can confirm their order.

Generation of QR Code and Order Number

Once the order is placed, a QR code will be generated through the app which is unique for different orders. This generated

code is sent to the canteen management side via the cloud and also to the Raspberry Pi. This code contains the details of what dish/menu and which student has ordered, with the order number.

Delivery of Order

A QR scanning machine will be installed at the canteen management side which will scan generated QR code via the Android app. As the QR code gets scanned at the canteen side, the canteen owner will come to know that you are present at the canteen side for taking your delivery. Once your order is ready from the kitchen, your order number will be displayed on the LCD screen, and also your number will be announced on the speaker. You just have to receive the order from the counter.

As you receive your order from the counter, the Raspberry Pi will make changes in the database that order is successfully delivered. Also, we required a power supply at the canteen side so that all these details are stored in the Raspberry Pi and also the canteen's server network to maintain a proper record of each order.

Validation of QR Code

The order will be valid for 60 minutes. The students can cancel their order within 60 minutes, and after 60 minutes, if students were unable to receive their order, the payment will not be returned to them (Dias B.L., 2020).

If the order is canceled before 45 minutes after the order is placed, the money will be refunded to the student's account. For example, if a student is using a digital wallet for the payment purpose, and when he/she asked for a refund, the refunded money is returned to the digital wallet. Sometimes there are possibilities of a network issue in the crowded area, so we have also provided Wi-Fi facility for the students so that problems that can occur during ordering the food can be reduced.

Payment Mode

For the payment mode, there we have provided two options as mentioned below:

- **Cards**

Debit and credit cards: Net banking facilities are provided to the user or students which makes the payment mode is easier. The user only has to add his/her card details in the app, which is safe. Once the card details are added the user can save it and use it again if he/she is ordering the food next time.

- **Digital Wallets**

There are various digital wallets app available which can be used for payment purpose. These are PayTM, PhonePe, MobiKwik, etc., which contain the user's banking details. Also, it has different cashback offers which basically attracts the user.

Menu Updating

The menu updating facility is not provided to the canteen owner but it is provided to the IT person who is handling

the software part of the Android app. If the owner needs any specific changes in the menu, he can ask the IT person, because the android coding part is difficult to understand for the canteen owner.

RESULTS

The results of this system are obtained using the Android application (Figure 2-6).



Figure 2: Home page of Android application

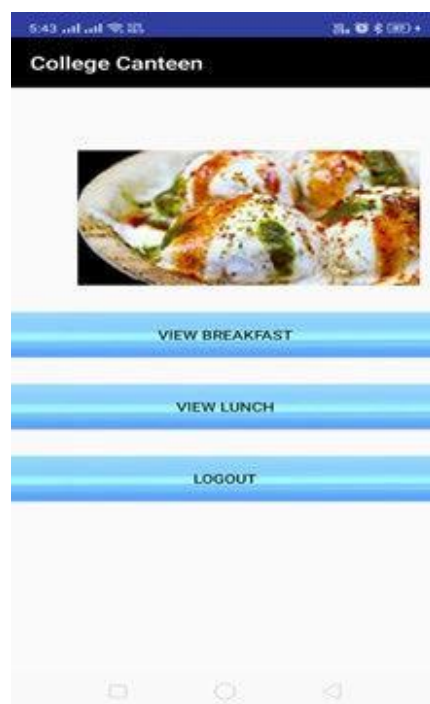

Figure 3: Menu selection from mobile app



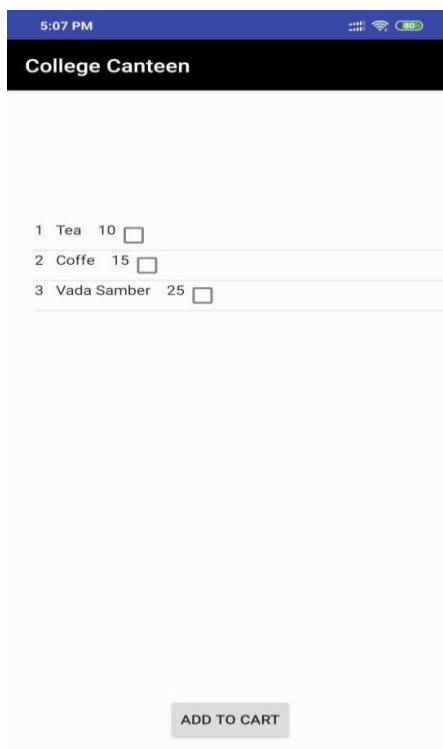

Figure 4: Dish selection page for breakfast

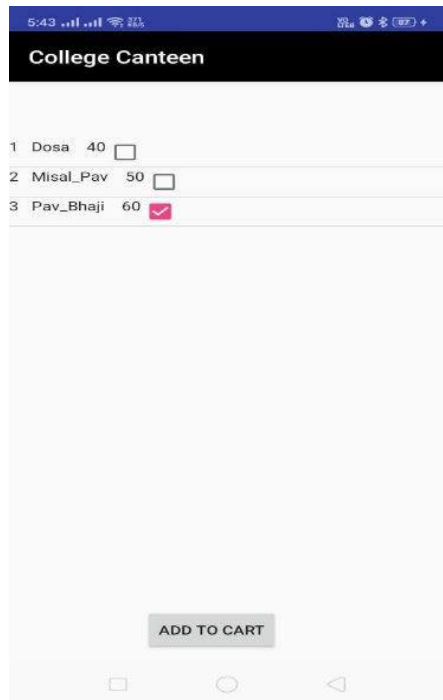

Figure 5: Dish selection page for lunch



Figure 6: QR code generation after order is confirmed

built-in JetBrains's IntelliJ IDEA software, it is available for all platforms, i.e., Windows, macOS, and Linux. Android Studio is basically the replacement of Eclipse Android Development Tools (ADT).

Features

- Gradle-based built-in support.
- Supported by the build-in Google cloud platform.
- Emulator to run and debug the app in android studio.
- A rich layout is provided for drag and drop options.
- For creating common Android designs and components, template-based wizards are there.
- Android-specific refactoring and quick fixes.

Xampp

Xampp is an open-source platform and free for web server solution stack package developed by Apache Friends, which basically stores the data. In our paper, the Xampp saves the database received from the Android app, i.e., when the user creates its account in the app, their details are saved in Xampp. If the customer or students saves some wrong information, then the IT person who is handling this app can edit their details using Xampp software.

CONCLUSION

The main aim of this paper was to develop an Android app to save the time for those students who are waiting in a long queue for ordering their food also again waiting in another queue to take their delivery.

In this system, we have created an Android app that is more attractive, time-saving, and informative than the normal canteen system. The processing speed of the Android

SYSTEM TECHNOLOGY

The software used for implementing the system are:

Android Studio

Android Studio is the official integrated development environment for developing any Android application. With

system is fastest as compared to the queuing-based systems. Therefore, it is clearly visible that Android-based systems are the cheapest automation solution for the canteen owners. Thus, we are providing an automated food ordering system using an Android app having features of wireless communication. This system is convenient, effective, and easy to use, thereby improving the performance of the canteen's staff and also the time of the students.

REFERENCES

- [1] Akash Katkar And Smita Jangale, "Canteen management system using E-wallet", International journal of advance research, idea and innovation, 2018.
- [2] Tazeen Khan and Daniel Yunus, "Cloud Based Canteen Management System", International Journal for Research in Engineering Application and Management (IJREAM) ISSN: 2494-9150 Vol-02, Issue 08, Nov 2016
- [3] Varsha Chavan, Priya Jadhav, Snehal Korade and Priyanka Teli, "Implementing Customizable Online Food Ordering System Using Web Based Application", in IJISSET-International Journal of Innovative Science, Engineering and Technology, Vol. 2 Issue 4, April 2015.
- [4] Nalluri, S. K., & Parasaram, V. K. B. (2015). Automating Software Builds with Jenkins: Design Patterns and Failure Handling. International Journal of Technology, Management and Humanities, 1(01), 16-33. <https://doi.org/10.21590/ijtmh.01.02.03>
- [5] Dias, B. L. (2020). Big Data in Public Health: Real-Time Epidemiology Using Mobility and Environmental Data to Predict Outbreaks. International Journal of Cell Science and Biotechnology, 9(01), 05-10.
- [6] Yao Xiaochun and Jiang Yuhong, "Canteen consuming management system design based on CAN and RFID", International Conference and Transportation, mechanical and electrical Engineering, 2011.
- [7] Rajesh Kannan and Sreenath P S, "Low Power Microcontroller Based Simple Smart Token Number Display System", International Conference on MEMS NANO, and Smart system, 2009.

